

POLYPIPE UNDERGROUND DRAINAGE SYSTEM

POLYPIPE COUPLINGS AND ADAPTORS

This Agrément Certificate Product Sheet⁽¹⁾ relates to Polypipe Couplings and Adaptors, 110 and 160 mm diameter polypropylene connectors for PVC-U/clay pipes, for use in domestic drainage of surface water or domestic waste water as is permitted to be discharged into public sewers.

(1) Hereinafter referred to as 'Certificate'.

CERTIFICATION INCLUDES:

- factors relating to compliance with Building Regulations where applicable
- factors relating to additional non-regulatory information where applicable
- independently verified technical specification
- assessment criteria and technical investigations
- design considerations
- installation guidance
- regular surveillance of production[†]
- formal three-yearly review.[‡]



KEY FACTORS ASSESSED

Flow characteristics — the products have sufficient flow characteristics (see section 6).

Strength — the products have adequate strength to resist the loads and impacts likely to be encountered during transport, installation and use (see section 7).

Performance of joints — the connections between the adaptors/couplers and the pipelines are watertight, and the trap is airtight (see section 8).

Durability — the material from which the products are manufactured will not deteriorate significantly and the anticipated service life of the products will be in excess of 50 years (see section 12).

The BBA has awarded this Certificate to the company named above for the products described herein. These products have been assessed by the BBA as being fit for their intended use provided they are installed, used and maintained as set out in this Certificate.

On behalf of the British Board of Agrément

Date of Third issue: 14 July 2022

Originally certificated on 29 March 1989



Hardy Giesler
Chief Executive Officer

This Certificate was amended on 22 May 2024 as part of a transition of The BBA Agrément Certificate scheme delivered under the BBA's ISO/IEC 17020 accreditation. This Certificate was issued originally under accreditation to ISO/IEC 17065. Sections marked with the symbol † are not issued under accreditation. Full conversion to the ISO/IEC 17020 format will take place at the next Certificate review. The BBA is a UKAS accredited Inspection Body (No.4345). Readers MUST check the validity of this Agrément Certificate by either referring to the BBA website or contacting the BBA directly. Any photographs are for illustrative purposes only, do not constitute advice and must not be relied upon.

Regulations

In the opinion of the BBA, Polypipe Couplings and Adaptors, if installed, used and maintained in accordance with this Certificate, can satisfy or contribute to satisfying the relevant requirements of the following Building Regulations (the presence of a UK map indicates that the subject is related to the Building Regulations in the region or regions of the UK depicted):



The Building Regulations 2010 (England and Wales) (as amended)

Requirement:	H1(1)	Foul water drainage
Comment:		The products will convey the flow of foul or surface water and minimise the risk of blockages or leakage. See sections 4.1, 6, 7 and 8 of this Certificate.
Requirement:	H3(3)	Rainwater drainage
Comment:		The products will convey the flow of foul or surface water and minimise the risk of blockages or leakage. See sections 4.1, 6, 7 and 8 of this Certificate.
Regulation:	7(1)	Materials and workmanship
Comment:		The products are acceptable. See section 12 and the <i>Installation</i> part of this Certificate.



The Building (Scotland) Regulations 2004 (as amended)

Regulation:	8(1)(2)	Durability, workmanship and fitness of materials
Comment:		The products satisfy the requirements of this Regulation. See sections 11 and 12 and the <i>Installation</i> part of this Certificate.
Regulation:	9	Building standards applicable to construction
Standard:	3.6	Surface water drainage
Standard:	3.7	Waste water drainage
Comment:		The products will satisfy the relevant requirements of these Standards, with reference to clauses 3.6.4 ⁽¹⁾⁽²⁾ to 3.6.6 ⁽¹⁾⁽²⁾ and 3.7.1 ⁽¹⁾⁽²⁾ . See sections 4.1, 6, 7 and 8 of this Certificate.
Standard:	7.1(a)	Statement of sustainability
Comment:		The products will contribute to meeting the relevant requirements of Regulation 9, Standards 1 to 6 and therefore will contribute to a construction meeting a bronze level of sustainability as defined in this Standard.
Regulation:	12	Building standards applicable to conversions
Comment:		All comments given for the products under Regulation 9, Standards 1 to 6 also apply to this Regulation, with reference to clause 0.12.1 ⁽¹⁾⁽²⁾ and Schedule 6 ⁽¹⁾⁽²⁾ .

(1) Technical Handbook (Domestic).

(2) Technical Handbook (Non-Domestic).



The Building Regulations (Northern Ireland) 2012 (as amended)

Regulation:	23(1)(a)(i)	Fitness of materials and workmanship
Comment:	(iii)(b)(i)	The products are acceptable. See section 12 and the <i>Installation</i> part of this Certificate.
Regulation:	79	Drainage systems
Comment:		The products are acceptable. See sections 4.1, 6, 7 and 8 of this Certificate.
Regulation:	81(a)	Underground foul drainage
Comment:		The products will convey the flow of foul or surface water and minimise the risk of blockages or leakage. See sections 4.1, 6, 7 and 8 of this Certificate.

Regulation: 82(a)

Rainwater drainage

Comment:

The products will convey the flow of rainwater and minimise the risk of blockages or leakage. See sections 4.1, 6, 7 and 8 of this Certificate.

Construction (Design and Management) Regulations 2015

Construction (Design and Management) Regulations (Northern Ireland) 2016

In the opinion of the BBA, there is no information in this Certificate which relates to the objections of the client, designer (including Principal Designer) and contractor (including Principal Contractor) under these Regulations.

Additional Information

NHBC Standards 2022

In the opinion of the BBA, Polypipe Couplings and Adaptors, if installed, used and maintained in accordance with this Certificate, can satisfy or contribute to satisfying the relevant requirements in relation to *NHBC Standards*, Chapter 5.3 *Drainage below ground*.

Technical Specification

1 Description

1.1 Polypipe Couplings comprise either a polypropylene body with ring seals retained by polypropylene snap caps at each end, or as a one piece comprising a body with an integrally formed groove to house the seal; in the latter case, the seal is located within the groove eliminating the need for snap caps. The ring seals are made from EPDM to BS EN 681-1 : 1996, Type WC. Each coupling is supplied assembled ready for use.

1.2 Polypipe Double Socket Adaptor comprises a polypropylene body with ring seals retained by polypropylene snap caps at each end (see Figure 1). One end is suitable for connection to PVC-U pipes or spigots to BS EN 1401-1 : 2019 and the other end is for connection to clay pipe with an external diameter between 115 and 124 mm for 110 mm pipe, and between 171 and 180 mm for the 160 mm pipe. Polypipe Socket/Spigot Adaptor is similar to the double socket adaptor but with a 110/160 mm diameter spigot.

Figure 1 Polypipe Adaptors

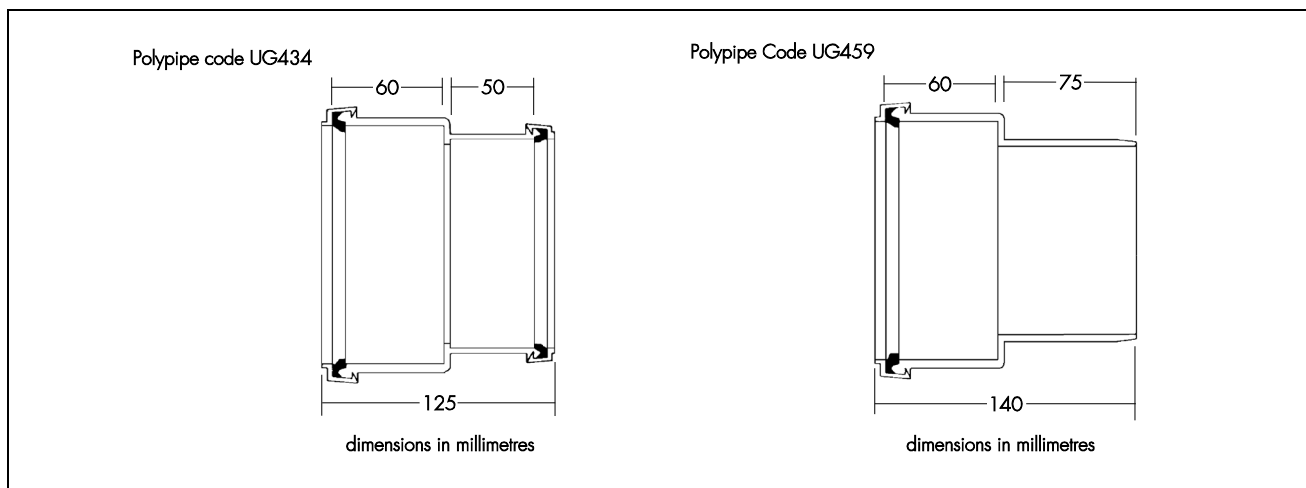

1.3 Products covered within this Certificate are listed in the Table 1.

Table 1 Fittings — product codes

Polypropylene fittings	Product code	
	110 mm	160 mm
Couplings		
Double socket	UG402	UG602
Slip double socket	UG402S	—
Super clay pipe adaptors		
Socket to PVC spigot	UG459	UG659
Socket to PVC socket	UG434	UG634

2 Manufacture

2.1 The coupling body, adaptor body and snap caps are injection-moulded from polypropylene.

2.2 As part of the assessment and ongoing surveillance of product quality, the BBA has:

- agreed with the manufacturer the quality control procedures and product testing to be undertaken
- assessed and agreed the quality control operated over batches of incoming materials
- monitored the production process and verified that it is in accordance with the documented process
- evaluated the process for management of nonconformities
- checked that equipment has been properly tested and calibrated
- undertaken to carry out the above measures on a regular basis through a surveillance process, to verify that the specifications and quality control operated by the manufacturer are being maintained.

2.3 The management system of Polypipe Building Products has been assessed and registered as meeting the requirements of BS EN ISO 9001 : 2015 and BS EN ISO 14001 : 2015 by BSI (Certificates FM00318 and EMS 732427 respectively)

3 Delivery and site handling.

3.1 Each coupling and adaptor is stamped with the Certificate holder’s logo and product code number, and carries a label bearing the BBA logo incorporating the number of this Certificate.

3.2 The products are supplied in polythene bags from which they should not be removed until required.

Assessment and Technical Investigations

The following is a summary of the assessment and technical investigations carried out on Polypipe Couplings and Adaptors.

Design Considerations

4 Use



4.1 Polypipe Couplings and Adaptors are satisfactory for use in domestic underground drains and public and private sewers for the conveyance, by combined or separate systems, of surface water or domestic sewage, as is permitted to be discharged into public sewers by the Water Industry Act 1991, and surface water and sewage as is permitted and defined by the Sewerage (Scotland) Act 1968 and the Water and Sewerage Services (Northern Ireland) Order 2006.

4.2 The products have not been assessed for use with untreated trade effluents and such use is outside the scope of this Certificate.

5 Practicability of installation

The products are designed to be installed by a competent general builder, or a contractor, experienced in below-ground drainage work.

6 Flow characteristics



The products have satisfactory flow characteristics associated with PVC-U underground sewerage systems.

7 Strength



The products will have adequate strength to resist all normal service loads associated with installation and use.

8 Performance of joints



8.1 When used in conjunction with underground pipes in accordance with BS EN 1401-1 : 2019, BS EN 13476-1 : 2018 and BS EN 13476-2 : 2018, or Polycore PVC-U Pipe, the joints remain watertight under conditions of pipeline movement in excess of those expected to occur in normal good drainage practice.

8.2 The performance of joints, when correctly made, will not be adversely affected by thermal expansion or contraction.

8.3 The restrictions on types of soil, depth of burial etc are applied to ensure that the soil loads and movements are accommodated by the products without detriment.

9 Resistance to chemicals

The products have adequate resistance to the type and quantity of chemicals likely to be found in domestic sewage.

10 Resistance to elevated temperatures

The products have adequate resistance to the normal temperature range of domestic sewerage.

11 Maintenance



Drains incorporating the products can be rodded using conventional flexible drain rods.

12 Durability



In the opinion of the BBA, no significant deterioration of the products will take place and the products will have a service life in excess of 50 years.

13 Reuse and recyclability

The products contain polypropylene, which can be recycled.

14 General

14.1 Underground drain and sewer systems incorporating the products should be installed in accordance with the recommendations of BS EN 752 : 2017, BS 8000-0 : 2014, BS 8000-14 : 1989, BS EN 1610 : 2015 and the Certificate holder's installation instructions.

14.2 Precautions must be taken to protect the products from damage during construction.

14.3 It is a requirement that a concrete backfill is provided in certain situations, and concrete of a suitable strength must be used.

14.4 Drains incorporating the products must be laid in a firm-sided trench with a depth no less than three times the pipe diameter and a width not exceeding 700 mm.

15 Procedure

Fittings

15.1 The spigot end and the inside of the socket must be clean and free from grit, dust and dirt. Lubricant should be applied evenly to the ring seal and fitting spigot/pipe ends.

15.2 The chamfered pipe is inserted into the socket, pushed fully home and afterwards withdrawn by approximately 10 mm, to provide an expansion gap.

15.3 The fittings may be used on offcuts of pipe provided the ends are cut square and adequately chamfered.

15.4 The couplers can be used as slip couplers if the 'knock-out' ribs are removed from the centre of the couplers in accordance with the Certificate holder's instructions. To achieve the correct insertion depth, the pipes are marked 45 mm from the end of each length to be joined. The coupler is slipped fully onto one of the pipes, the pipes are located in their final position and the coupler is eased into its correct position so that the insertion marks are visible at each end of the coupler.

Pipe laying on trench bottom in granular material

15.5 Where the as-dug material is suitable⁽¹⁾ for use as bedding, the bottom of the trench may be trimmed to form the pipe bed.

(1) Suitable material is defined as granular material having a nominal particle size not exceeding 10 or 14 mm for 110 and 160 mm diameter pipes, respectively.

15.6 Small depressions should be made to accommodate the pipe sockets or couplings. After the pipe has been laid these should be filled carefully to ensure that no voids remain under the socket.

15.7 When the formation is prepared, the pipes should be laid upon it true to line and level within the specified tolerances. Each pipe should be checked and any necessary adjustments to level made by raising or lowering the formation, ensuring that the pipes finally rest evenly on the adjusted formation throughout the length of the barrels. Adjustment should never be made by local packing.

15.8 Where the formation is low and does not provide continuous support, it should be brought up to the correct level by placing and compacting suitable material.

Figure 2 Pipe-laying specifications

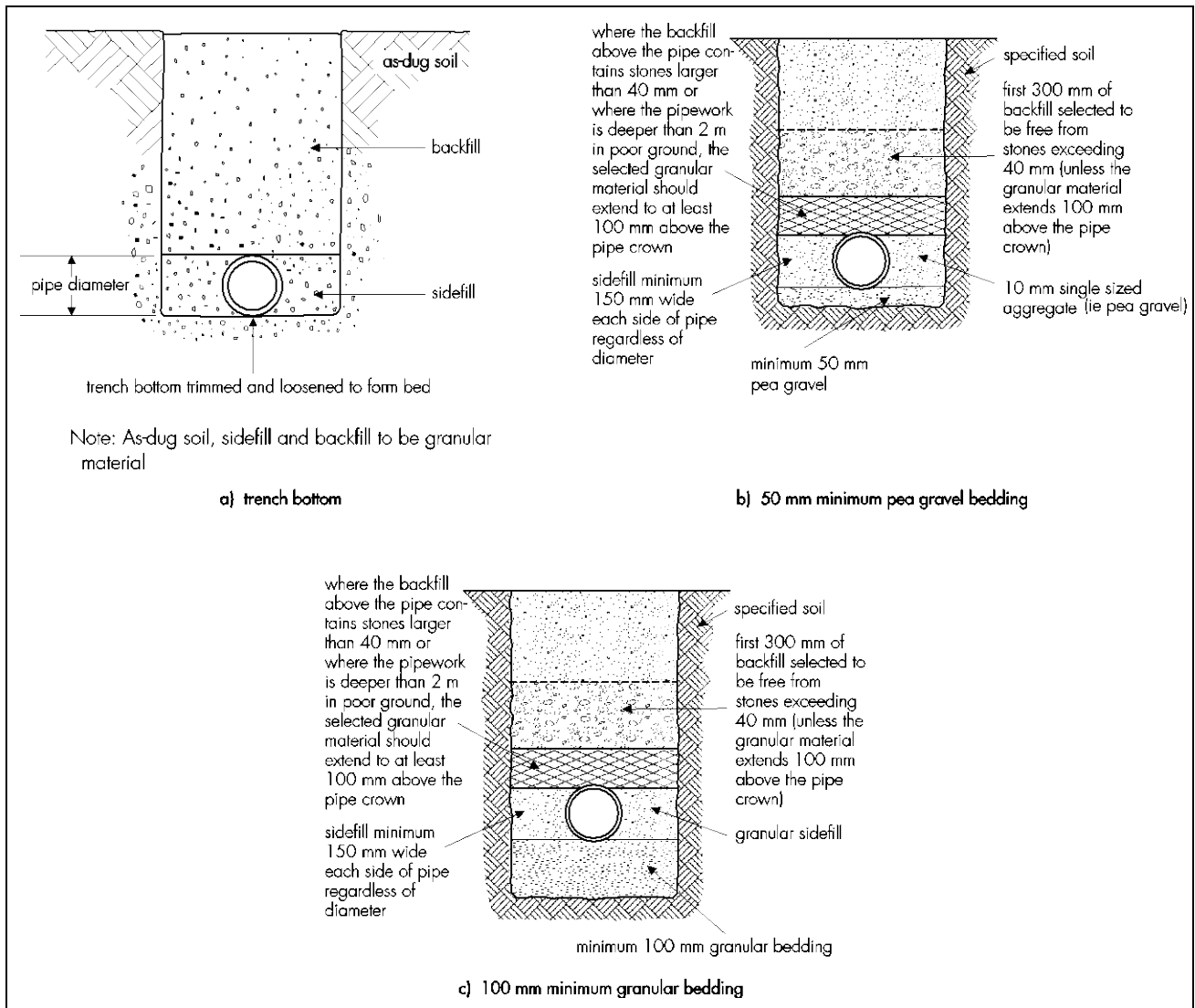

Pipe laying on granular beds

15.9 When the as-dug material is not suitable as a bedding, a layer of suitable granular material must be spread evenly across the total width of the trench bottom before the pipes are installed. The trench should be excavated to allow for the thickness of granular bedding under the barrels.

15.10 The trench formation should be prepared, the bedding placed and the pipes laid.

15.11 Where the trench bottom can be hand trimmed by shovel and is not puddled when walked upon, a 50 mm depth of bedding material may be used. In this case the material must be nominal 10 mm single-sized aggregate, ie pea gravel.

15.12 When the pipe is to be laid in rock, compacted sand and gravel requiring mechanical means of trimming and in very soft or wet ground, the bedding should be a minimum of 100 mm.

Sidefill

15.13 In all cases, the sidefill must be of the same specification as the bedding material and extend to the level of the crown of the pipe, and be placed and compacted.

Backfill

15.14 Specifications for backfill above the level of the crown of the pipe are shown in Figure 2.

16 Tests

Tests were carried out on the products and the results assessed to determine:

- effect of combined temperature cycling and external loading
- leak tightness when subjected to 10% pipeline deformation
- leak tightness when subjected to a pipeline deflection of 2°
- leak tightness when subjected to side and vertical displacements of up to 20 mm
- dimensional checks.

17 Investigations

17.1 An evaluation of existing data was made to determine:

- resistance to chemicals
- suitability of sealing rings
- quality of the moulding
- durability.
- practicability of installation.

17.2 The manufacturing process was evaluated, including the methods adopted for quality control, and details were obtained of the quality and composition of the materials used.

17.3 A visit to a site in progress was made to establish the ease of assembly of the couplings and adaptors in site conditions.

Bibliography

BS 8000-0 : 2014 *Workmanship on construction sites — Introduction and general principles*

BS 8000-14 : 1989 *Workmanship on building sites — Code of practice for below ground drainage*

BS EN 681-1 : 1996 *Elastomeric seals — Material requirements for pipe joint seals used in water and drainage applications — Vulcanized rubber*

BS EN 752 : 2017 *Drain and sewer systems outside buildings*

BS EN 1401-1 : 2019 *Plastics piping systems for non-pressure underground drainage and sewerage — Unplasticized poly(vinylchloride) (PVC-U) — Specifications for pipes, fittings and the system*

BS EN 1610 : 2015 *Construction and testing of drains and sewers*

BS EN 13476-1 : 2018 *Plastics piping systems for non-pressure underground drainage and sewerage — Structured-wall piping systems of unplasticized poly(vinyl chloride) (PVC-U), polypropylene (PP) and polyethylene (PE) — General requirements and performance characteristics*

BS EN 13476-2 : 2018 *Plastics piping systems for non-pressure underground drainage and sewerage — Structured-wall piping systems of unplasticized poly(vinyl chloride) (PVC-U), polypropylene (PP) and polyethylene (PE) — Specifications for pipes and fittings with smooth internal and external surface and the system, Type A*

BS EN ISO 9001 : 2015 *Quality management systems — Requirements*

BS EN ISO 14001 : 2015 *Environmental management systems — Requirements with guidance for use*

Conditions of Certificate

Conditions

1. This Certificate:

- relates only to the product that is named and described on the front page
- is issued only to the company, firm, organisation or person named on the front page – no other company, firm, organisation or person may hold or claim that this Certificate has been issued to them
- is valid only within the UK
- has to be read, considered and used as a whole document – it may be misleading and will be incomplete to be selective
- is copyright of the BBA
- is subject to English Law.

2. Publications, documents, specifications, legislation, regulations, standards and the like referenced in this Certificate are those that were current and/or deemed relevant by the BBA at the date of issue or reissue of this Certificate.

3 This Certificate will be displayed on the BBA website, and the Certificate Holder is entitled to use the Certificate and Certificate logo, provided that the product and its manufacture and/or fabrication, including all related and relevant parts and processes thereof:

- are maintained at or above the levels which have been assessed and found to be satisfactory by the BBA
- continue to be checked as and when deemed appropriate by the BBA under arrangements that it will determine
- are reviewed by the BBA as and when it considers appropriate.

4. The BBA has used due skill, care and diligence in preparing this Certificate, but no warranty is provided.

5. In issuing this Certificate the BBA is not responsible and is excluded from any liability to any company, firm, organisation or person, for any matters arising directly or indirectly from:

- the presence or absence of any patent, intellectual property or similar rights subsisting in the product or any other product
- the right of the Certificate holder to manufacture, supply, install, maintain or market the product
- actual installations of the product, including their nature, design, methods, performance, workmanship and maintenance
- any works and constructions in which the product is installed, including their nature, design, methods, performance, workmanship and maintenance
- any loss or damage, including personal injury, howsoever caused by the product, including its manufacture, supply, installation, use, maintenance and removal
- any claims by the manufacturer relating to UKCA, UKNI or CE marking.

6. Any information relating to the manufacture, supply, installation, use, maintenance and removal of this product which is contained or referred to in this Certificate is the minimum required to be met when the product is manufactured, supplied, installed, used, maintained and removed. It does not purport in any way to restate the requirements of the Health and Safety at Work etc. Act 1974, or of any other statutory, common law or other duty which may exist at the date of issue or reissue of this Certificate; nor is conformity with such information to be taken as satisfying the requirements of the 1974 Act or of any statutory, common law or other duty of care.

British Board of Agrément

1st Floor, Building 3, Hatters Lane
Croxley Park, Watford
Herts WD18 8YG

©2024

tel: 01923 665300
clientservices@bbacerts.co.uk
www.bbacerts.co.uk