

| Revisions | | | |
|-----------|-----------------|----------|----------|
| Rev | Modification No | Date | Approved |
| 01 | M-3765 | 31/01/13 | MUS |

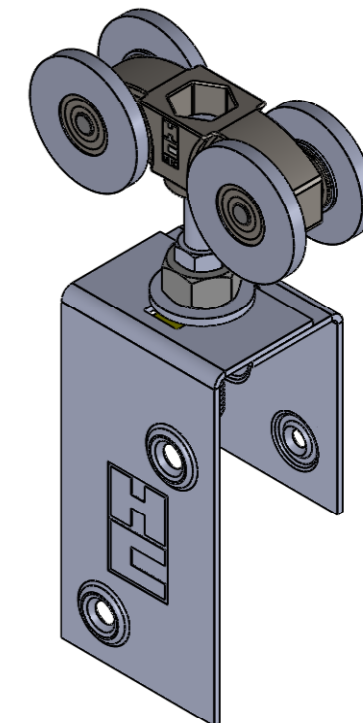

| ITEM NO. | PART NUMBER | DESCRIPTION | QTY. |
|----------|-------------|-------------------------------------|----------|
| 1 | 02200.55 | New No2 Hanger Steel wheels | 2 |
| 2 | 09021.101 | PENDANT BOLT '2 TRACK' 09021.101 | 2 |
| 3 | 03025.123 | M12 HEX. NUT | 2 |
| 4 | 09121.101 | CROWN NUT No.2 HANGER | 2 |
| 5 | 03028.122 | PLAIN WASHER | 2 |
| 6 | 09150.03 | APRON (LONG) '2' TRACK | 2 |
| 7 | 09150.04 | APRON (SHORT) '2' TRACK | 2 |
| 8 | 03025.131 | Half nut | 4 |
| 9 | 03004.21 | Screw pack | 2 |
| 10 | 06426.08 | Hanger fitting instructions | 1 |
| 11 | 06022.47 | Bar code | 1 |
| 12 | 055 labour | pack in pairs | 2.016 hr |

**New part No: 02247 replacing
Old part No: 02201**

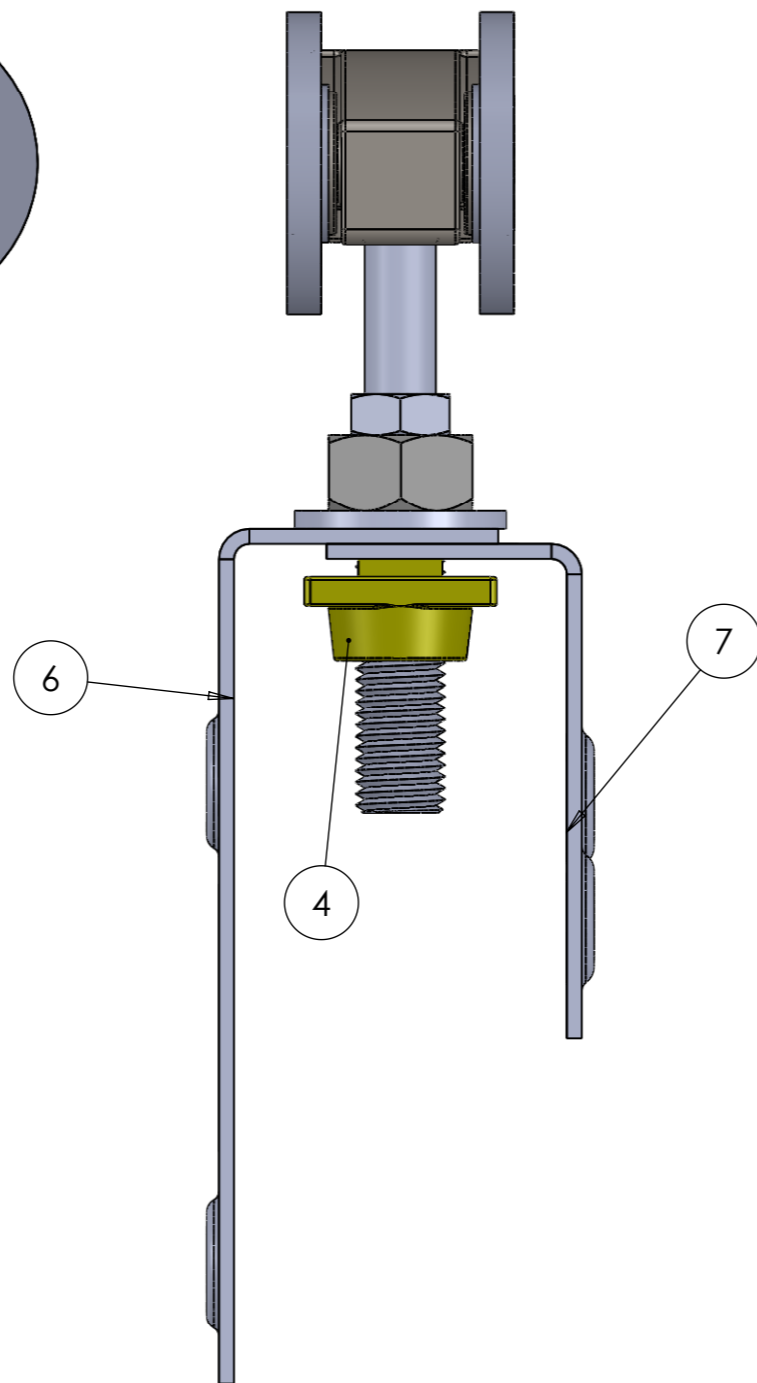
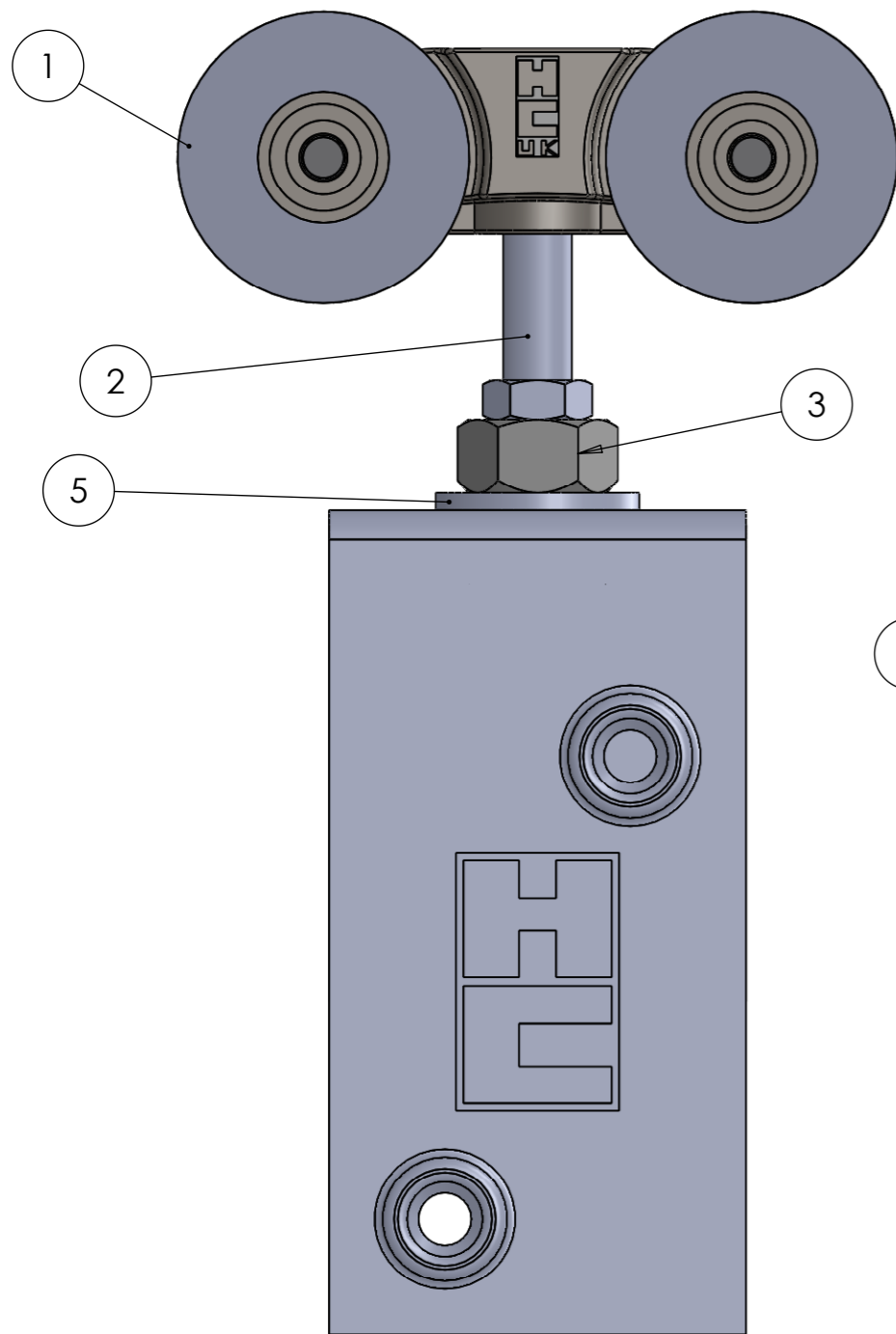

HILLDAM COBURN LTD
UNIT 16, MERTON INDUSTRIAL PARK
LEE ROAD, LONDON
SW19 3HX,
UK
TEL:+44 (020) 8545 6680 FAX:+44 (020) 8545 6723
E-Mail:sales@hillaldam.co.uk
Web:www.coburn.co.uk

| | | | | | | | | |
|--|--------|---|--|------------|---------------|--|------------|--|
| MATERIAL | Steel | UNLESS OTHERWISE SPECIFIED: | DRAWN | DATE | FILE DRG. No. | 1/02247/ | | |
| FINISH | silver | DIMENSION(mm) TOLERANCE ZERO PL DECIMAL ±0.2 ONE PL DECIMAL ±0.1 TWO PL DECIMAL ±0.05 | MUS | 31/01/2013 | TITLE: | New No 2 steel wheel Hanger Assy for wooden doors | | |
| COPYRIGHT HILLDAM COBURN LTD © | | ANGULAR TOLERANCE ±0.5° | CHECKED | DATE | SIZE | DRG/PART. No. | REV | |
| THE INFORMATION CONTAINED IN THIS DRAWING IS THE SOLE PROPERTY OF <HILLDAM COBURN LTD>. ANY REPRODUCTION IN PART OR AS A WHOLE WITHOUT THE WRITTEN PERMISSION OF <HILLDAM COBURN LTD> IS PROHIBITED. | | FORGING TOLERANCE SEE BS 4114 | MUS | 31/01/2013 | A4 | 02-247 | 01 | |
| | | COMMENTS: REMOVE ALL SHARP EDGES AND BURRS | DIMENSIONS ARE IN mm DO NOT SCALE DRAWING | | SCALE: NTS | WEIGHT: | SHEET: 1/1 | |